

Installation manual Operating instructions

Solar combi buffer tank tank-in-tank

WPKR 750 - 1000



Installation and commissioning must be undertaken by a specialist.

General terms and conditions of warranty state that all installations must be carried out by a suitably trained and qualified plumber who observes the local norms and regulations.

The installation and maintenance record must be entirely completed and the user has to be instructed accordingly.

Efficient operation can only be guaranteed if the instructions of this manual are followed.

Warranty does not cover any damage caused due to non-observance of this manual and the technical rules in force.

The system is to be checked annually by a specialized company. In addition, occurring defects must be repaired immediately.

This document should be handed over to the client on completion of the installation.

Index

1	General	2
2	Transport and installation	2
3	Dimensions and connections	3
4	Technical data	4
5	Installation	5
6	Commissioning	6
7	Maintenance and wear parts	6
8	Recycling and disposal	6
9	Warranties and guarantee	7
10	Installation record	8

1 General

Depending on the type and design, WIKORA tanks are suitable for heating and / or storing DHW and / or heating water. The heating is achieved indirectly via heat generators, if applicable, from different heat sources. The maximum working pressure and working temperature can be found in the technical data.

Set-up, installation and commissioning must be undertaken by a qualified specialist, who must observe these instructions.

The site of installation must be frost-protected according to DIN 4753 and should be in direct proximity to the heat generator.

When setting-up and installing the tank, the following regulations should be considered:

In addition to the technical rules in force DIN 1988, DIN 18160, DIN 4753, DIN 4109, DIN 4708, DIN 4751 section 2-4 energy conservation law and VDE regulations are to be observed. Moreover, the relevant regulations of the suppliers as well as legal building regulations are to be considered.

DHW requirements:

- Minimum hardness:
 - 2° dh (sum of alkaline earths 0,4 mmol/l)
- Conductivity
 - if external current anode is used $\geq 100 \mu\text{s/cm}$
 - if Mg-anode is used 130 $\mu\text{s/cm}$ – 1500 $\mu\text{s/cm}$
- pH-value according to Drinking Water Ordinance (6,5-9,5)

Important: The exhaust pipe must be at least as big as the safety valve outlet in width. It may not have more than 2 bends and should not be longer than 2 m. If for any compelling reasons 3 bends or a length up to 4 m are required, then the entire exhaust line must be designed one nominal size larger. More than 3 bends, or a length exceeding 4 m is prohibited. The exhaust pipe must be installed with downward gradient. The drain line behind the funnel must feature at least the double width of the valve entrance. A sign is to be attached close to the exhaust pipe of the safety valve or on the safety valve itself. „For safety reasons water may leak from the exhaust pipe during the heating process! Do not lock! "The operability of the safety valve is to be checked at regular intervals by means of de-ventilation.

2 Transport and installation

In order to prevent damage during transport, the packaging should only be removed at the site of installation. During shipment, it should be ensured that the tank does not come in contact with any spiky or sharp items, nor is damaged through dropping or knocks.

During installation, the tank must be disconnected from any humidity carrying components. Moreover, sufficient space for maintenance and cleaning purposes should be kept free in front of, beside, above and behind the tank.

Please note that the insulation provided should be kept in a dry place at least 24 hours at a minimum temperature of 20°C before installation.

3 Dimensions and connections

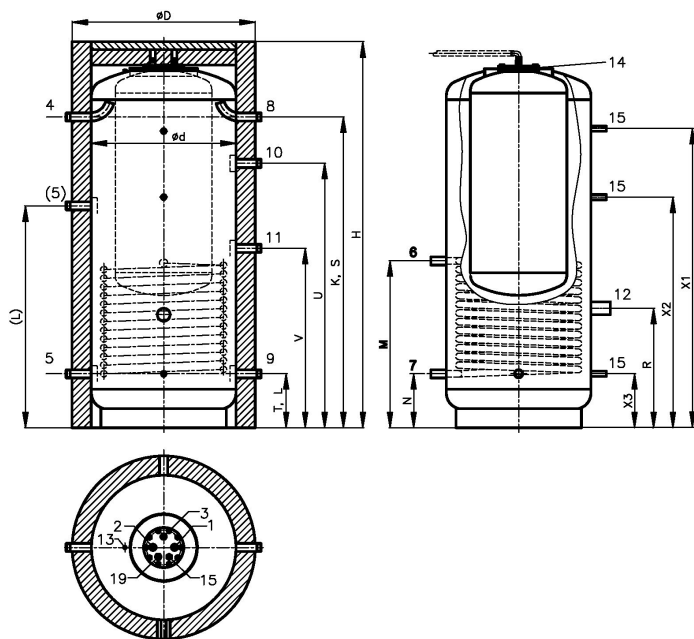

Illustration1

Dimensions:

Type	ϕd	ϕD	H	K	L (L)	M	N	R	S	T	U	V	W	X1	X2	X3
	[mm]	[mm]	[mm]	[mm]	[mm]	[mm]	[mm]	[mm]	[mm]	[mm]	[mm]	[mm]	[mm]	[mm]	[mm]	[mm]
WPKR 750	750	950	2000	1610	280 (1150)	865	280	620	1610	280	1370	930	1950	1550	1195	280
WPKR 1000	850	1050	1990	1590	280 (1150)	865	280	580	1590	280	1350	950	1950	1530	1195	280

Chart 1

W = Tilting dimension

Connections:

Type			WPKR 750	WPKR 1000
Cold water / hot water	1/2	Ga	$\frac{3}{4}$	$\frac{3}{4}$
Circulation	3	Ga	$\frac{3}{4}$	$\frac{3}{4}$
Aux boiler flow / return	4/5	Ga	5/4	5/4
Solar flow / return	6/7	Gi	1	1
Load flow / return	8/9	Ga	5/4	5/4
Heating flow / return	10/11	Ga	5/4	5/4
Plug for electric heater	12	Gi	6/4	6/4
Vent	13	Gi	1/8	1/8
Inspection flange	14	NW	142	142
Sensor socket	15	Gi	$\frac{1}{2}$	$\frac{1}{2}$
Anode	19	Gi	$\frac{3}{4}$	$\frac{3}{4}$

Chart 2

Ga = male thread
Gi = female thread

4 Technical data

Description		WPKR 750	WPKR 1000
Storage volume (real) acc. to DIN EN 12897/Nominal volume DHW	[litre]	724/201	922/201
Max. working temperature buffer / DHW / heat exchanger	[°C]	95 / 95 / 160	95 / 95 / 160
Max. working pressure buffer / DHW / heat exchanger	[bar]	3 / 10 / 10	3 / 10 / 10
Capacity of heat exchanger	[litre]	23	25
Heating area DHW tank	[m ²]	2,0	2,0
Surface of heat exchanger	[m ²]	2,7	3,0
Flow rate of heat exchanger	[m ³ /h]	5,0	5,0
Pressure drop of heat exchanger	[mbar]	340	380
Insulation		100 mm fleece insulation	
Nominal Load N _L (according to DIN 4708)		ca. 2,9	ca. 2,9
Standing loss	[Watt]	129	143
Energy efficiency class		-	-
Weight (empty)	[kg]	ca. 240	ca. 280

Chart 3

5 Installation

All pipes connecting to the tank should have removable connections (fitting/flange). Pipe thread seals with teflon are to be avoided.

All tank connecting pipes are to be planned, constructed and tested according to the technical rules in force, as well as to the corresponding norms and regulations in accordance with their application and supply medium.

Appropriate filters should be used to prevent dirt or particles from entering the tanks. Moreover, the tank should be ensured against pressure fluctuations and excess pressure through the installation of tested pressure reducing valves and safety valves.

Sensors and thermostats necessary for temperature control must be securely and permanently positioned on the tank (immersion sleeve and sensor rail).

The tank's venting and draining facilities must have the appropriate dimensions and be correctly installed.

The installation company is responsible for the correct execution of work and for the safe and careful insulation of the pipes.

- When connecting to a solar plant, a temperature limiter is required and must be installed on site at the hot water outlet in order to prevent scalding.

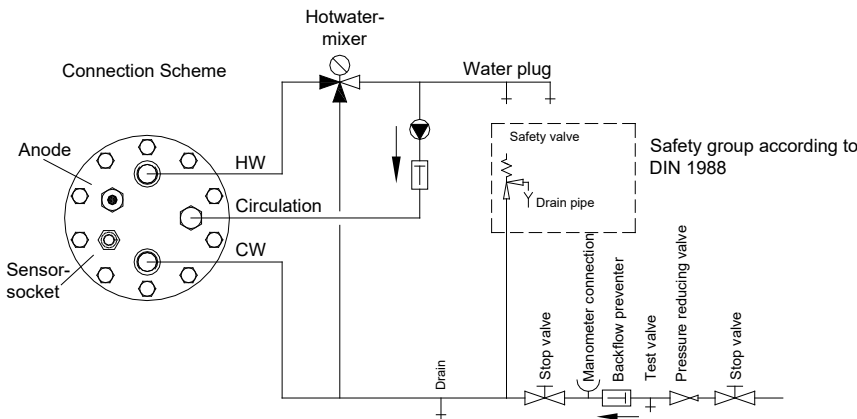

Illustration 2 (Schematic diagram)

The size of the DHW safety valve is shown below:

Content of DHW space	Min. valve size	Max. heating performance
up to 200 l	NW 15 (1/2")	75 kW
above 200 to 1000 l	NW 20 (3/4")	150 kW

When installing a circulation pipe, the plug in the flange cover must be replaced by a circulation connection attachment (plastic immersion pipe with double nipple R 3/4", Wikora part number 096 090).

The thread diameter of the heating safety valve depends on the nominal capacity of the water space and the maximum heating capacity of the heat generator. It can be determined as follows:

Reaction pressure	Max. heating capacity of the heat generator					
1,5 bar	36 kW	72 kW	144 kW	252 kW	433 kW	650 kW
2,0 bar	43 kW	86 kW	172 kW	302 kW	518 kW	778 kW
2,5 bar	50 kW	100 kW	200 kW	350 kW	600 kW	900 kW
3,0 bar	56 kW	112 kW	224 kW	395 kW	678 kW	1017 kW
Thread diameter (inch)	1/2	3/4	1	5/4	6/4	2

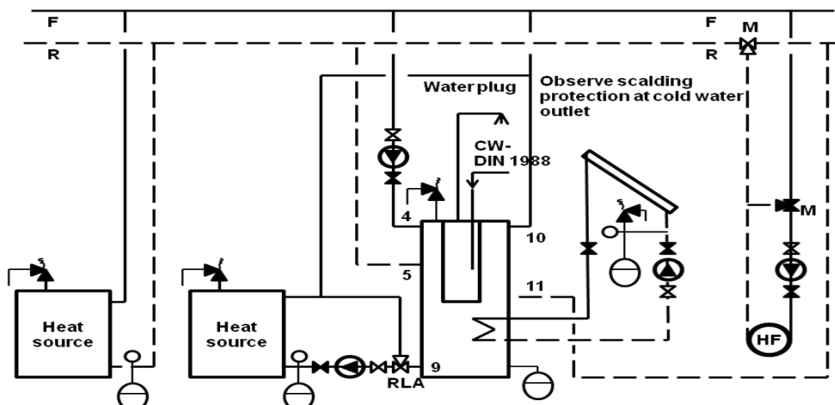

Illustration 3 (Schematic drawing– example hydraulic system heating)

6 Commissioning

- Before putting into operation, the entire system should be flushed through. Particles in the system compromise the operating reliability.
- When filling the system, fill the DHW tank first and put pressure on it. Open the **cold water stop valve** and all hot water nozzles. The tank is full when water leaks out of all hot water nozzles. Then close all nozzles again.
- Fill the heating system slowly with water and vent all the air.
- Start-up the heating system.
- Set the DHW temperature and supervise the system while heating up.
- While the System is heating up, water will leak out of the safety valve.
- **After the tank has heated up and cooled down for the first time, the flange screws must be retightened by means of a set torque wrench and the flange connection should be checked for tightness.**

Torque chart

External diameter of flange/ Diameter of pitch circle	Torque Nm
170 / 145 mm	32 Nm
180 / 150 mm	32 Nm
210 / 180 mm	40 Nm
280 / 245 mm	70 Nm

- **Before the handover of the system to the end user/owner, the plumbing contractor should ensure that the system is tested to full load, controls are set and that pipe work and connections are without leaks.** Afterwards, the end user has to be instructed in the operation and handling of the tank, as well as the system. The instruction must be documented in the installation and maintenance record.,
- Please note that the operation and lifetime of the system depend decisively on a regular maintenance.

7 Maintenance and wear parts

Un entretien régulier augmente la longévité et la sécurité de fonctionnement du ballon. Si l'eau est très calcaire, il pourra s'avérer nécessaire de procéder à un détartrage à intervalles réguliers.

1. Pour inspecter la cuve intérieure et l'échangeur, fermer la vanne d'arrêt d'eau froide et vidanger le ballon. Couper tous les dispositifs électriques reliés à l'appareil. Retirer ensuite prudemment l'isolation de la bride d'obturation, puis dévisser et ôter cette dernière. Les dépôts calcaires ou de gros résidus calcaires peuvent être éliminés à l'aide d'un racloir en bois. N'utiliser que les détartrants autorisés. Une fois le nettoyage terminé, bien visser la bride d'obturation et mettre en place un nouveau joint pour la bride. Procéder ensuite à un nouveau remplissage du ballon en eau et vérifier son étanchéité. Pour finir, remettre en place l'isolation et les éventuels dispositifs électriques qui ont été démontés.
Un détartrage chimique au moyen de produits appropriés peut être entrepris par du personnel qualifié. Lors du détartrage chimique, le ballon doit être séparé de l'installation d'e.c.s. (eau froid / eau chaude / circulation). Il est recommandé d'observer les mesures de sécurité adéquates.
2. Le ballon est équipé d'une anode sacrificielle en magnésium. Sa dissolution dépend de la composition de l'eau. Elle devra être inspectée pour la première fois après 2 ans de service et ensuite une fois tous les ans afin de contrôler son état. Son diamètre doit correspondre au moins à 1/3 de son diamètre d'origine et sa surface doit être suffisamment homogène et exempte de dépôts calcaires. Si nécessaire, elle sera remplacée par une anode sacrificielle Wikora d'origine afin de protéger le ballon contre la corrosion.
2.a. Alternativement, les ballons peuvent être équipés d'une anode à courant imposé. Cependant, la protection contre la corrosion est seulement garantie si l'anode est dûment connectée.
Le fait de négliger l'entretien de l'anode peut entraîner des dommages dus à la corrosion ainsi que la perte de la garantie.
3. La soupape de sécurité a pour fonction de protéger le ballon contre la surpression. Pour cette raison, il est indispensable de vérifier régulièrement sa fonctionnalité en la manœuvrant. En cas d'installation de vases d'expansion, la soupape de sécurité n'est pas ou très rarement sollicitée. Elle risque de s'encrasser au bout d'un certain temps et de ne plus être opérationnelle en cas de besoin.
4. Lorsqu'il y a risque de gel, le ballon doit être constamment chauffé ou bien être vidangé complètement.
5. Pour le nettoyage de la partie extérieure, un chiffon humide suffit. Ne jamais utiliser de détergents abrasifs ou de solvants.

8 Recycling and disposal

The products are specified and manufactured according to VDI 2243. The products are mechanically separable and 100% recyclable. Make sure that the components are disposed according to the relevant regulations.

9 Warranties and guarantee

The warranty for our products is based on the legal provisions of the general Civil Code and the Consumer Protection Act.

In addition, defective appliances are replaced within the framework of our full warranty within 1 year, as of the date of the invoice, including the replacement, procurement and incidental costs. As far as our hot-water heaters and pressurized boilers are concerned, the warranty amounts for 6 months, as of the date of the invoice.

Subsequent to the full warranty, defective tanks are replaced within the framework of our guarantee. The guarantee of the different products and the conditions are shown in the table below.

All other claims are excluded. Repairs and costs which occur due to damage, inappropriate installation, chemical, electrochemical or electrical influences, incorrect operation or improper manipulation, are excluded. Furthermore, the warranty becomes invalid if the appliance has been modified through the installation of externally supplied parts or through irregular professional maintenance.

Subject to our general terms and conditions.

Products	Legal warranty 2 years	Guarantee years*	Conditions
DHW storage tanks			
WBO T/ToF	•	5	20 / 27
WBL	•	5	20 / 27
WBO Uno	•	5	20 / 27
WBO Duo	•	5	20 / 27
WP/Sol	•	5	20 / 27
WBO H	•	5	20 / 27
GS	•	5	20 / 27
Combi buffer tanks			
Wikosol Twin	•	10	27
Wikosol	•	10	27
WPKR H Twin	•	5	20 / 27
WPKR Twin	•	5	20 / 27
WPKR	•	5	20 / 27
WPK	•	5	20 / 27
WPH-FW (tank)	•	5	27
WPR-FW (tank)	•	5	27
Buffer tanks			
WPS	•	5	20 / 27
WPH	•	5	-
WPR	•	5	-
WPRR	•	5	-
WKS	•	5	-
Tank accessories			
Cu-finned tube heat exchanger	•	-	27
Electric heating element	•	-	-

Conditions:

- | | |
|----|--|
| 20 | Under condition that the limits of the valid DHW regulations have been respected, the anode has been examined for the first time after 2 years and afterwards annually and that the anode has been replaced by an original Wikora anode (individual receipts needed) by a specialized company. |
| 27 | Coverage Germany:
Compliance with the limits of the valid DHW regulations (TrinkwV 2001), especially the limits in accordance with Appendix 2, Part 1-2 and Appendix 3
Coverage EU :
Compliance with the limits of the EG-Regulations 83/98 |

* Start of guarantee at date of invoice

10 Installation record

The installation has been completed according to DIN and the technical rules in force. In addition, the customer has received instruction concerning the operation and maintenance.

Place..... Date.....

Customer Installer

..... Signature Signature

Place of installation:

Name:

ZIP Code/Place:

Street:

Phone:

Tank model: Serial number

Date of invoice

Anode maintenance record

Date	Visual examination of anode	Exchange of anode	Signature + stamp of installer

In the case of reclamation, the receipts for maintenance must be provided as proof. Please complete the data sheet, including the reason for reclamation, and submit to Wikora.

Submitting the maintenance record does not ensure any promise of guarantee or claim.