

Installation manual Operating instructions

Heating buffer tank with one heat exchanger

WPR 605 - 3005



Installation and commissioning must be undertaken by a specialist.

General terms and conditions of warranty state that all installations must be carried out by a suitably trained and qualified plumber who observes the local norms and regulations.

The installation and maintenance record must be entirely completed and the user has to be instructed accordingly.

Efficient operation can only be guaranteed if the instructions of this manual are followed.

Warranty does not cover any damage caused due to non-observance of this manual and the technical rules in force.

The system is to be checked annually by a specialized company. In addition, occurring defects must be repaired immediately.

This document should be handed over to the client on completion of the installation.

Index

1	General	2
2	Transport and installation	2
3	Dimensions and connections	3
4	Technical data	4
5	Installation	4
6	Commissioning	5
7	Maintenance and wear parts	5
8	Recycling and disposal	5
9	Warranties and guarantee	6
10	Installation record	7

1 General

Depending on the type and design, WIKORA tanks are suitable for heating and / or storing DHW and / or heating water. The heating is achieved indirectly via heat generators, if applicable, from different heat sources. The maximum working pressure and working temperature can be found in the technical data.

Set-up, installation and commissioning must be undertaken by a qualified specialist, who must observe these instructions.

The site of installation must be frost-protected according to DIN 4753 and should be in direct proximity to the heat generator.

When setting-up and installing the tank, the following regulations should be considered:

In addition to the technical rules in force DIN 1988, DIN 18160, DIN 4753, DIN 4109, DIN 4708, DIN 4751 section 2-4 energy conservation law and VDE regulations are to be observed. Moreover, the relevant regulations of the suppliers as well as legal building regulations are to be considered.

Important: The exhaust pipe must be at least as big as the safety valve outlet in width. It may not have more than 2 bends and should not be longer than 2 m. If for any compelling reasons 3 bends or a length up to 4 m are required, then the entire exhaust line must be designed one nominal size larger. More than 3 bends, or a length exceeding 4 m is prohibited. The exhaust pipe must be installed with downward gradient. The drain line behind the funnel must feature at least the double width of the valve entrance. A sign is to be attached close to the exhaust pipe of the safety valve or on the safety valve itself. „For safety reasons water may leak from the exhaust pipe during the heating process! Do not lock! "The operability of the safety valve is to be checked at regular intervals by means of de-ventilation.

2 Transport and installation

In order to prevent damage during transport, the packaging should only be removed at the site of installation. During shipment, it should be ensured that the tank does not come in contact with any spiky or sharp items, nor is damaged through dropping or knocks.

During installation, the tank must be disconnected from any humidity carrying components. Moreover, sufficient space for maintenance and cleaning purposes should be kept free in front of, beside, above and behind the tank.

3 Dimensions and connections

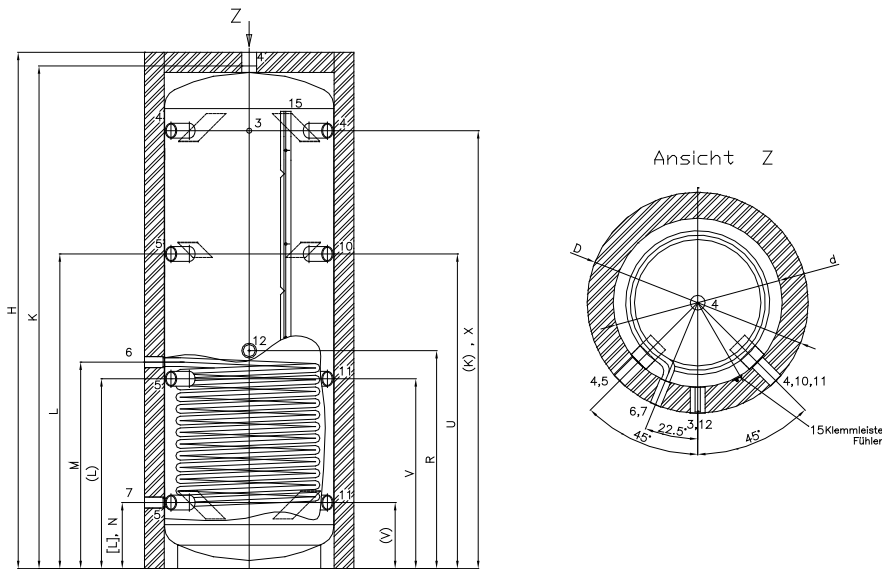

Illustration 1

Dimensions:

Type	d	D	H	K (K)	L (L) [L]	M	N	R	U	V (V)	W	X
	[mm]	[mm]	[mm]	[mm]	[mm]	[mm]	[mm]	[mm]	[mm]	[mm]	[mm]	[mm]
WPR 605	650	850	2008	1933 (1684)	1210 (730) [254]	794	254	838	1210	730 (254)	1960	1684
WPR 805	790	990	1880	1802 (1520)	1020 (700) [290]	830	290	980	1020	700 (290)	1845	1520
WPR 1005/790	790	990	2192	2117 (1835)	1340 (740) [290]	875	290	980	1340	740 (290)	2150	1835
WPR 1005/850	850	1050	1940	1867 (1590)	1150 (720) [280]	865	280	950	1150	720 (280)	1910	1590
WPR 1505	1000	1240	2150	2074 (1730)	1340 (740) [350]	935	350	1050	1340	740 (350)	2130	1730
WPR 2005	1200	1440	2090	2013 (1625)	1300 (720) [395]	935	395	1050	1300	720 (395)	2100	1625
WPR 3005	1250	1450	2680	2603 (2220)	1700 (930) [390]	1200	390	1500	1700	930 (390)	2670	2220

Chart 1

W = Tilting dimension

Connections:

Type			WPR 605	WPR 805	WPR 1005/790	WPR 1005/850	WPR 1505	WPR 2005	WPR 3005
Thermometer	3		x	x	x	x	x	x	x
Aux boiler flow / return	4/5	Gi	6/4	6/4	6/4	6/4	2	2	2
Solar flow / return upper / lower	6/7	Gi	1	1	1	1	1	5/4	5/4
Heating flow / return	10/11	Gi	6/4	6/4	6/4	6/4	2	2	2
Plug for electric heater	12	Gi	6/4	6/4	6/4	6/4	2	2	2
Sensor clamp	15		x	x	x	x	x	x	x

Chart 2

Gi = female thread

If necessary, baffle plates can be pushed aside with a bluff item (e.g. for the installation of an electric back-up heater).

4 Technical data

Type		WPR 605	WPR 805	WPR 1005 / 790	WPR 1005 / 850	WPR 1505	WPR 2005	WPR 3005
Storage volume (real) acc. to DIN EN 12897	[litre]	598	825	978	978	1529	2003	2930
Max. working temperature buffer / heat exchanger	[°C]	95 /160	95 /160	95 /160	95 /160	95 /160	95 /160	95 /160
Max. working pressure buffer / heat exchanger	[bar]	3 / 10	3 / 10	3 / 10	3 / 10	3 / 10	3 / 10	3 / 10
Capacity of heat exchanger	[litre]	13,5	18,0	20,0	20,0	25,0	27,0	40,0
Surface of heat exchanger	[m ²]	2,0	2,7	3,0	3,0	3,7	4,0	6,0
Pressure loss of heat exchanger	[mbar]	70	90	95	95	180	205	313
Insulation		100 mm Neopor/fleece				120 mm Neopor/fleece		100 mm fleece
Flow rate of heat exchanger	[m ³ /h]	1,5	1,5	1,5	1,5	2,0	2,0	2,5
Standing loss	[Watt]	117	134	140	138	163	183	-
Energyefficiency class		-	-	-	-	-	-	-
Weight (empty)	[kg]	132	169	213	213	254	314	387
Recommended min. gross collector surface*		8,0	10,0	12,0	12,0	18,0	20,0	30,0

Chart 3

* for flat plate collectors

5 Installation

All pipes connecting to the tank should have removable connections (fitting/flange). Pipe thread seals with teflon are to be avoided.

All tank connecting pipes are to be planned, constructed and tested according to the technical rules in force, as well as to the corresponding norms and regulations in accordance with their application and supply medium.

Sensors and thermostats necessary for temperature control must be securely and permanently positioned on the tank (immersion sleeve and sensor rail).

The tank's venting and draining facilities must have the appropriate dimensions and be correctly installed.

The installation company is responsible for the correct execution of work and for the safe and careful insulation of the pipes.

The thread diameter of the heating safety valve depends on the nominal capacity of the water space and the maximum heating capacity of the heat generator. It can be determined as follows:

Reaction pressure	Max. heating capacity of the heat generator					
1,5 bar	36 kW	72 kW	144 kW	252 kW	433 kW	650 kW
2,0 bar	43 kW	86 kW	172 kW	302 kW	518 kW	778 kW
2,5 bar	50 kW	100 kW	200 kW	350 kW	600 kW	900 kW
3,0 bar	56 kW	112 kW	224 kW	395 kW	678 kW	1017 kW
Thread diameter (inch)	1/2	3/4	1	5/4	6/4	2

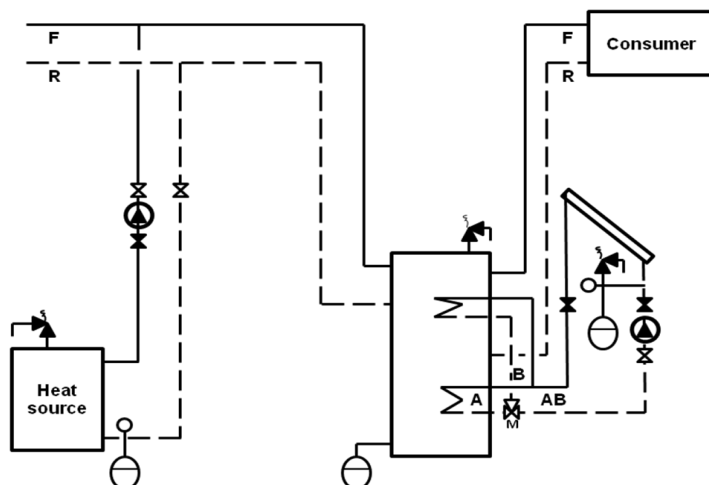

Illustration 2 (Schematic drawing– example hydraulic system heating)

6 Commissioning

- Before putting into operation, the entire system should be flushed through. Particles in the system compromise the operating reliability.
- Fill the heating system slowly with water and vent all the air.
- Start-up the heating system.
- While the System is heating up, water will leak out of the safety valve.
- **Before the handover of the system to the end user/owner, the plumbing contractor should ensure that the system is tested to full load, controls are set and that pipe work and connections are without leaks.** Afterwards, the end user has to be instructed in the operation and handling of the tank, as well as the system. The instruction must be documented in the installation and maintenance record.,
- Please note that the operation and lifetime of the system depend decisively on a regular maintenance.

7 Maintenance and wear parts

Regular maintenance increases the lifetime and operation reliability of the system. Decalcification at regular intervals may be necessary in highly calcareous water areas. **Attention – only valid for heating tanks with hot water supply.**

A chemical decalcification can be carried out by a specialist using an approved decalcifier and taking the appropriate precautions.

1. The safety valve protects the tank against excess pressure. The functional capacity must be checked at regular intervals by venting. If an expansion vessel is used, the safety valve is not, or only rarely, required. Over a longer period of time therefore, it can become blocked and not function when needed.
2. If there is a danger of freezing, the DHW tank should be permanently heated or completely emptied.
3. A damp cloth is sufficient to clean the outer parts. Please avoid using any abrasive or solvent cleaning.

8 Recycling and disposal

The products are specified and manufactured according to VDI 2243. The products are mechanically separable and 100% recyclable. Make sure that the components are disposed according to the relevant regulations.

9 Warranties and guarantee

The warranty for our products is based on the legal provisions of the general Civil Code and the Consumer Protection Act.

In addition, defective appliances are replaced within the framework of our full warranty within 1 year, as of the date of the invoice, including the replacement, procurement and incidental costs. As far as our hot-water heaters and pressurized boilers are concerned, the warranty amounts for 6 months, as of the date of the invoice.

Subsequent to the full warranty, defective tanks are replaced within the framework of our guarantee. The guarantee of the different products and the conditions are shown in the table below.

All other claims are excluded. Repairs and costs which occur due to damage, inappropriate installation, chemical, electrochemical or electrical influences, incorrect operation or improper manipulation, are excluded. Furthermore, the warranty becomes invalid if the appliance has been modified through the installation of externally supplied parts or through irregular professional maintenance.

Subject to our general terms and conditions.

Products	Legal warranty 2 years	Guarantee years*	Conditions
DHW storage tanks			
WBO T/ToF	•	5	20 / 27
WBL	•	5	20 / 27
WBO Uno	•	5	20 / 27
WBO Duo	•	5	20 / 27
WP/Sol	•	5	20 / 27
WBO H	•	5	20 / 27
GS	•	5	20 / 27
Combi buffer tanks			
Wikosol Twin	•	10	27
Wikosol	•	10	27
WPKR H Twin	•	5	20 / 27
WPKR Twin	•	5	20 / 27
WPKR	•	5	20 / 27
WPK	•	5	20 / 27
WPH-FW (tank)	•	5	27
WPR-FW (tank)	•	5	27
Buffer tanks			
WPS	•	5	20 / 27
WPH	•	5	-
WPR	•	5	-
WPRR	•	5	-
WKS	•	5	-
Tank accessories			
Cu-finned tube heat exchanger	•	-	27
Electric heating element	•	-	-

Conditions:

- | | |
|----|--|
| 20 | Under condition that the limits of the valid DHW regulations have been respected, the anode has been examined for the first time after 2 years and afterwards annually and that the anode has been replaced by an original Wikora anode (individual receipts needed) by a specialized company. |
| 27 | Coverage Germany:
Compliance with the limits of the valid DHW regulations (TrinkwV 2001), especially the limits in accordance with Appendix 2, Part 1-2 and Appendix 3
Coverage EU :
Compliance with the limits of the EG-Regulations 83/98 |

* Start of guarantee at date of invoice

10 Installation record

The installation has been completed according to DIN and the technical rules in force. In addition, the customer has received instruction concerning the operation and maintenance.

Place..... Date.....

Customer Installer

.....
Signature Signature

Place of installation:

Name:

ZIP Code/Place:

Street:

Phone:

Tank model: Serial number

Date of invoice

In the case of reclamation, the receipts for maintenance must be provided as proof. Please complete the data sheet, including the reason for reclamation, and submit to Wikora.

Submitting the maintenance record does not ensure any promise of guarantee or claim.